

**Repower GGC-150V-100A
Technical Specification**

Model: GGC-150V-100A

Shenzhen RePower Technology Co., Ltd

Date: May 2025

1. Battery Pack Testing Platform

1.1. Overview

This equipment for power - battery packs (finished products/semi - finished products) is mainly used for the testing of charging and discharging of battery packs, testing of load - bearing capacity, measurement of DCIR (DC Internal Resistance), measurement of ACR (AC Resistance), calibration of current, measurement of resistance signals, testing of communication functions, and testing of insulation withstand voltage performance, etc., for automatic testing.

This equipment integrates charge - discharge system, AC internal resistance meter, insulation withstand voltage meter, environmental temperature detection module, communication module, relay switching system, and supporting PC software. It can estimate product qualification according to battery detection process parameters, automatically record and save test data, and upload the data to the MES system. It is mainly applied to the functional testing and quality control of semi - finished and finished products in the production process of power - battery packs for electric tools, electric bicycles and electric tricycles and energy storage power station, etc.

1.2. Environment Requirements and Technical Parameters

A.Power supply: AC voltage $380V \pm 10\%$, frequency: $50\text{ HZ} \pm 5\%$;

B.Environmental temperature: $10^{\circ}\text{C}\sim 45^{\circ}\text{C}$;

C.Environmental Humidity: $\leq 85\% \text{R.H}$ (non-condensing) ;

D. Environment requires No strong vibration, no corrosive gases and no flammable and explosive gases;

2. Main test supported

Function types	Function description
Basic functions	WakeUp activation test
	Open circuit voltage test
	ACR(AC internal resistance) test
	Load capacity test
	DCIR(DC internal resistance) test
	Charging and Dis-charging test
	Charging and Discharging Over current test
	Charging and Discharge Over current Delay test

	NTC(Negative Temperature Coefficient Thermistor) resistance test
	ID resistance(Identity Resistor) test
	Test of communication functions such as First-line serial、Rs485 and CAN
BMS communication test function (freely debug two battery packs with communication modules)	BMS current accuracy calibration
	Charging and Discharging current acquisition accuracy test
	Total voltage acquisition accuracy test
	Temperature reading and consistency test for cell
	Voltage reading and consistency test for cell
	SOC(State of Charge) reading and adjusting test
	Reading test such as SOH(state of Health) and RTC(Real Time Clock)
	Reading of firmware version
	Writing and comparative test of SN code
	Read the alarm information of the Battery Module
	Test of receiving and sending communication instructions
Other testing function	Input/Output Control Test; This equipment can output high and low level voltage, and then test whether the IO port of the battery pack can work properly, such as the ON enable signal, charging and discharging enable signal
	Testing of power output voltage signal of battery pack

3. Equipment components and technical parameters

3.1. Components

No.	Item	Description	Number	Unit	Remark
1	Charging and Discharging system	RCDS-150V100A	1	channel	
2	ACR(AC internal resistance) tester	/	1	pcs	
3	Insulation resistance	/	1	pcs	
4	Relay switching module	/	1	pcs	
5	Signal inheritance module	/	1	pcs	
6	CAN Communication Box	/	1	pcs	
7	RS485 communication module	RP-RS485	1	pcs	
8	Computer	I5/16G/500G	1	pcs	
9	PC software	GGC testing software for PC	1	pcs	
10	Output line	GGC-CSX-100	1	pcs	

11	Power input line	/	1	pcs	
----	------------------	---	---	-----	--

3.2. Technical parameters

No.	parameters	mode: GGC-150V100A	
1	Rated value range (0°C-40°C)	Output Voltage	7V~150V
		Output Current	-100A~100A
		Output Power	-15KW~15KW
2	Output Accuracy (@25±5°C)	Voltage Accuracy	±0.05%FS
		Current Accuracy	±0.05%FS
3	Acquisition Accuracy (@25±5°C)	Voltage Accuracy	±0.05%RD
		Current Accuracy	±0.05%RD
4	resolution	Voltage resolution	1mV
		Current resolution	1mA
5	Response time (10%~90%FS)	Response time of current	≤20ms
6	Open Circuit Voltage measurement	Range of voltage	0.1V~150V
		Current acquisition Accuracy	±0.05%
7	AC internal resistance(ACR) test	Measurement range if resistance	1mΩ~3000mΩ
		Measurement Accuracy (@25±5°C)	±0.5%
8	Loading function test	Range of current	0.3A~100A
		Discharge waste	0.6s~120s
9	DCIR(DC internal resistance) test	Range of Current	-100A~100A
		Constantly Output	1s~120s
10	Over Current test	Range of current	5A~100A
		Constantly Output	1s~120s
11	Over current delay test	Range of lasting	10ms~90000ms
12	CAN Communication	CAN Channel	2 Channel
		CAN Communication protocol	CAN2.0A and CAN2.0B
		Communication baud rate	40Kbps~1Mbps
13	Detection of Signal	Measurement of DC voltage (@25±5°C)	4channels :0~6V; Accuracy of Acquisition: ±0.05%FS; 4 Channels:0~50V; Accuracy of

			Acquisition:±0.05%FS; 4 Channels:0~150V; Accuracy of Acquisition:±0.05%FS;
		Measurement of NTC and ID resistance	4 Channels:1Ω~1MΩ; Accuracy of measurement:±1%FS±1Ω;
		Measurement of Temperature	1 Channel: -20°C~120°C; Accuracy of Acquisition±1.5°C;
		Output of Relay's Dry contact one	9 Channels 30V1A; state: always opening;
		Output of Relay's Dry contact two	3 Channels 200V1A; state:always opening;
		Detection of Relay's Dry contact	4 Channels
		Output of Source	1 Channel: 3.3V50mA; 1 Channel: 5V500mA; 1 Channel: 12V1000mA;
14	Features of system	Input mode and Output mode	Support same port and divided port battery test; 4 electrode collection mode; Customized fixture according to different tests; The length of the collection cable is 1~5 meters.;
15		Date of test	Generate data tables and save them automatically; they can be uploaded to MES
16		Management of code	Support scanning code to start and bind test data
17		Cooling (interior 22°C)	Ventilation and cooling fan
18	Maintenance	Warranty	1 year;
19		Repair ability	Modular, Can replace spare parts、Timely replacement and repair of spare parts, Free serve in Warranty period;
20		Software Update	Support to upgrade unless hardware does not allow ;

4. Appearance and Dimension

4.1. Appearance



Note: Appearance is subject to the delivery of the Records of the Grand Historian

4.2. Dimensions (mm)

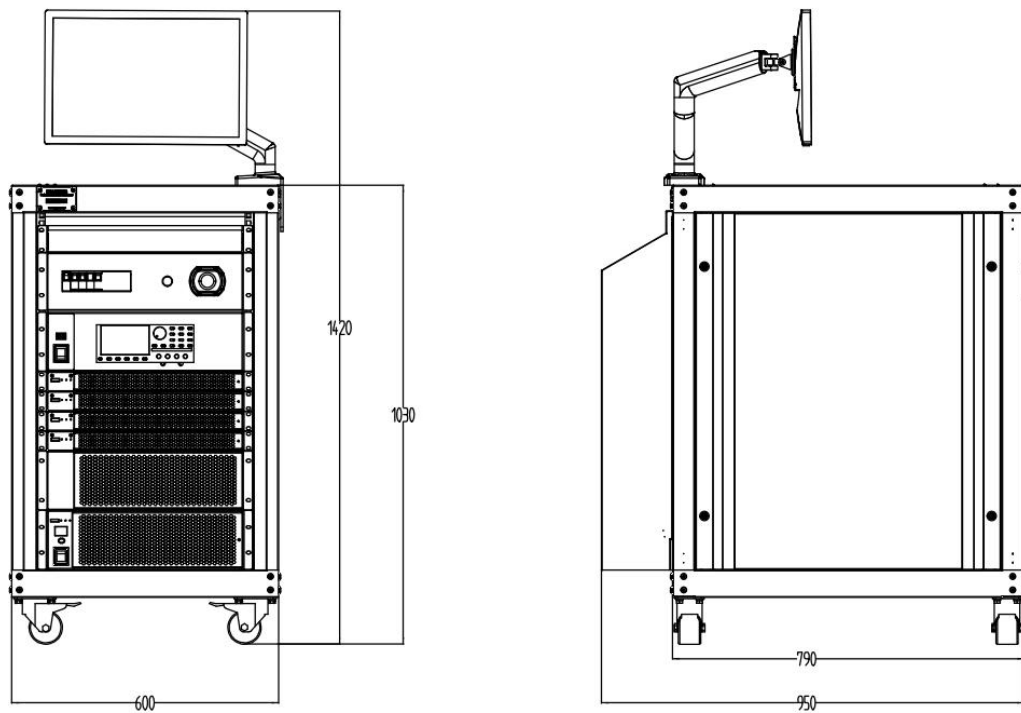

5. PC Software

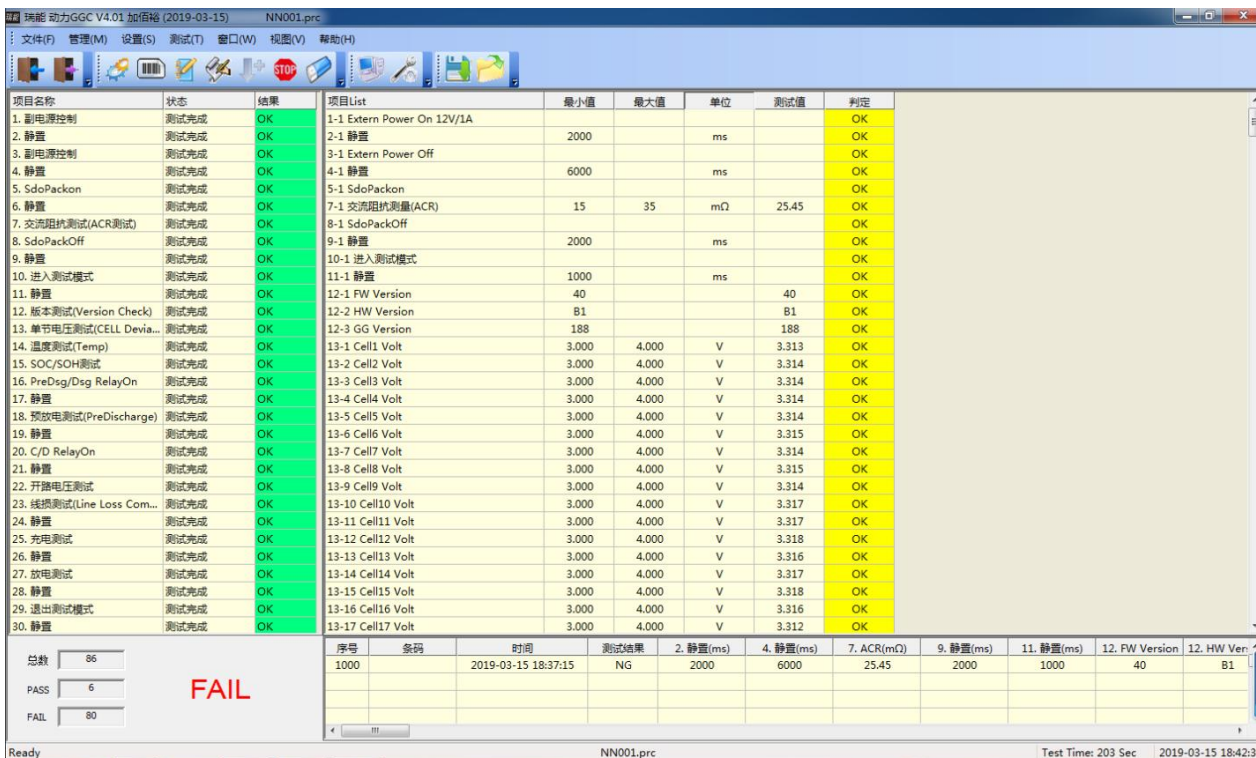

6. Basic parameters

No.	Items	Technical parameter
1	Dimensions	≤600*950*1030mm (W*D*H)
2	Weight	≤400KG
3	Channel	1 Channel
4	Operation	Manual wiring;Automotive testing ,Up to one test can be tested at the same time

7. Scope of Supply

No.	Item	Customer	Supplier
1	Battery pack connection cable、 Special connection cable and plug terminal	√	
2	Tested tooling and fixtures	√	
3	Test equipment and test cabinets (cabinet include electronic circuit)		√
4	380V power input cable (Default: 5 m)		√
5	Computer (host、 Mouse、 Keyboard and Monitor)		√
6	PC Software		√
7	Docking service for Testing equipment and MES		√

备注：设备供货范围边界如上表，验收时以测试设备方供货范围作为分界点单独验收。

8. Contact Information

Company: RePower Technology Co., Ltd.

Address: Shangzhi Science and Technology Park, Guangming Avenue, Tangwei Community, Fenghuang Street, Guangming District, Shenzhen, CN

Telephone: +86-755-26703611/26703711/26703811

Taxes: +86-755-2167-8812 Post code: 518055

Website: www.repower.cn

Marketing: marketing@repower.cn

Official Wechat account:



RePower Technical Support WeChat:

