

BATTERY TESTING EQUIPMENT & AUTO-LINE SOLUTION PROVIDER

Battery Test System
Battery Formation And Grading System Solution
Module / Pack Automated Production Line Solution

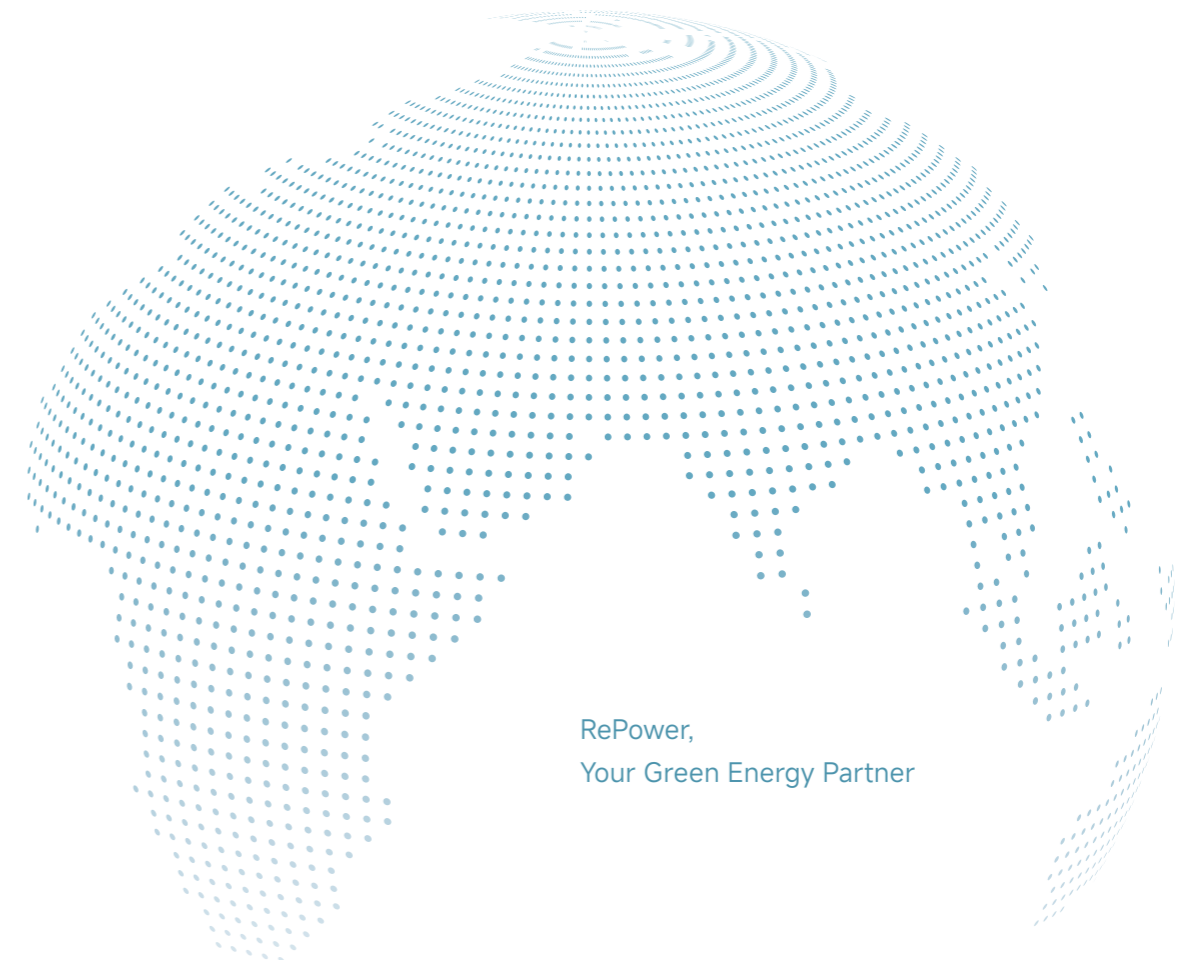

RePower,
Your Green Energy Partner

Add : Block A & B, Building 3, Shangzhi Science and Technology Park, No. 380
Guangming Avenue, Guangming District, Shenzhen,China
TEL: +86-755-26703611
Email: marketing@repower.cn
Website: www.repowerglobal.com



Note: The copyright belongs to RePower Technology Co., Ltd, confidential information is prohibited be used or spread without the permission of RePower.

REPOWER TECHNOLOGY CO., LTD.



About RePower

RePower Technology Co., Ltd. was established in 2003. Main business includes various battery charge and discharge testing system, PACB / BMS / EOL testing system, overall solutions for battery automation production lines, energy storage system solutions, etc. As an independent research and development manufacturing enterprise, RePower has three major production bases in Shenzhen and Dongguan, with over 1200 employees and about 40% of technical personnel.

As one of the earliest battery testing brands in China, RePower has a leading technological level and is a designated new energy project cooperation unit by the national government. Its business scope covers dozens of countries and regions such as Japan, South Korea, Southeast Asia, Europe, and the Americas. With high-quality products and services, it has been widely praised by the market and customers.

Battery Test Solution

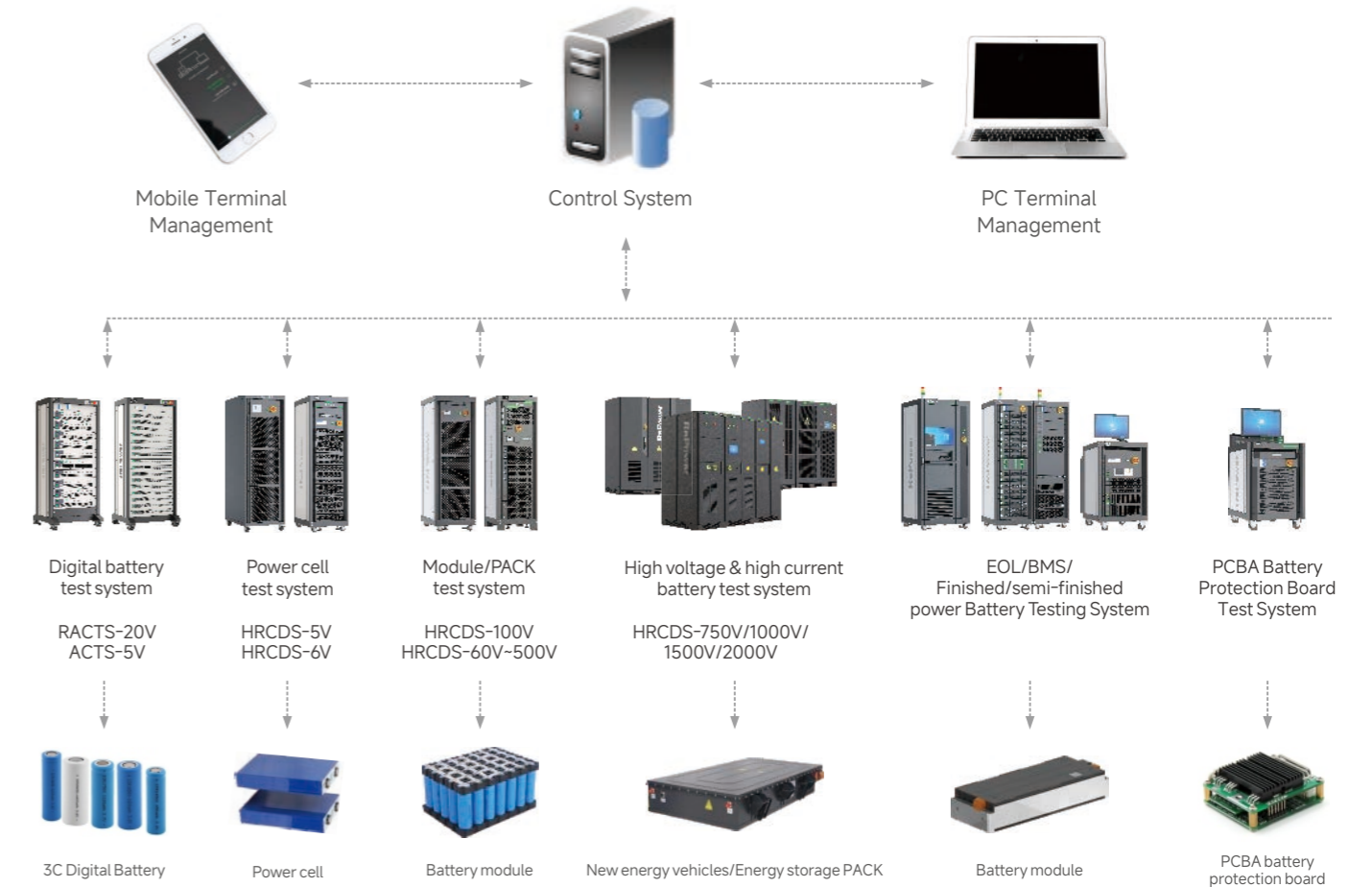

Customers



Distributed 5V Cell Tester

HRCDS-5V300A-HV
HRCDS-5V600A-HV
HRCDS-5V1000A-HV



Parameter

Single-channel Rated Current	300A/600A/1000A...
Voltage accuracy	±0.02%F.S
Current accuracy	±0.02% F.S, multi-range selectable
Minimum output current	25mA
Current response time	< 3ms (10%~90%F.S)
Current switching time	< 6ms (-90%~90%F.S)
Sampling time	10ms
Operating condition pulse (pulse width)	20ms
In parallel	Support ≥4CH lossless parallel connection
Communication methods	LAN

Note:For specific models and parameters, please refer to the corresponding technical specifications.

Function Test

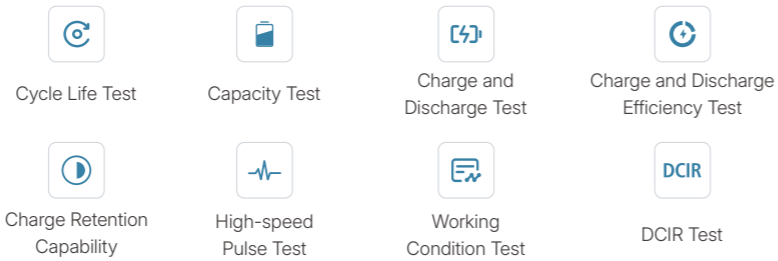

Applications

RePower distributed cell test equipment is a new-generation regenerative test system based on the high-voltage bus scheme and centered on energy management strategy.It is specially designed for lithium battery cells used in new energy vehicles and energy storage sectors, and applicable to multiple scenarios including R&D verification, production quality inspection and performance optimization.

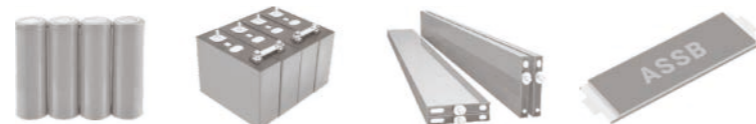

Advantages

- High-voltage bus architecture with distributed layout and EMS, feedback efficiency up to 85%, saving about 40% energy vs conventional solutions;
- Automatic multi-range current switching supported;
- Supports 200% overload operation for 60s, delivers high current output without extra hardware;
- Supports high-speed pulse test with 20ms pulse width;
- Offline operation ≥24H after network disconnection, seamless resumption to ensure full data integrity;
- Supports multi-dimensional matrix test;
- Intelligent linkage with water chiller, temperature chamber, pressure sensor and other third-party devices.

Power Cell Tester

HRCDS-5V600A-LV

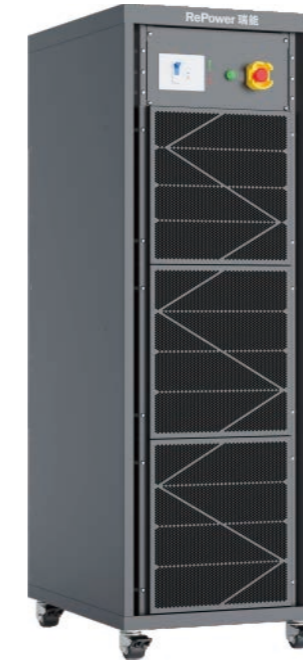

Parameter

Single-channel Rated Current	600A
Voltage accuracy	±0.02%F.S
Current accuracy	±0.02% F.S, multi-range selectable
Minimum output current	25mA
Current response time	< 3ms (10%~90%F.S)
Current switching time	< 6ms (-90%~90%F.S)
Sampling time	10ms
Operating condition pulse (pulse width)	20ms
In parallel	Support ≥4CH lossless parallel connection
DCIR test	Supports 1.2x power continuous operation for 180s
Communication methods	LAN

Note:For specific models and parameters, please refer to the corresponding technical specifications.

Function Test

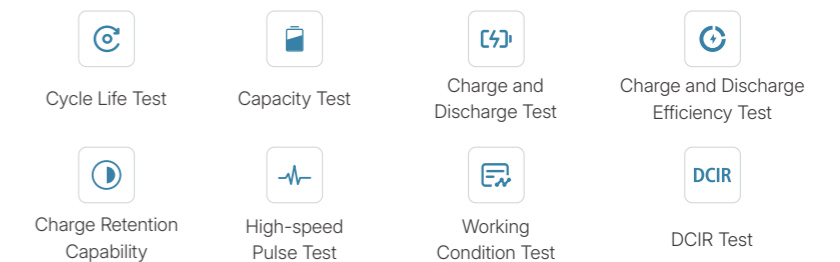

Applications

RePower 5V series power battery test system is applicable to lithium, lead-acid, Ni-Cd and Ni-MH batteries for electrical performance testing.It perfectly simulates real road conditions, performs high-precision real-time sampling, data storage, analysis and early warning, providing reliable data support for battery R&D and production.



Advantages

- High-quality discharge energy feedback to grid, peak efficiency ≥85%;
- Automatic multi-range current switching supported;
- 1.2x continuous power operation for 180S; short-term high current output without extra hardware;
- High-frequency modular design, flexible combination for customized requirements;
- High-speed pulse test available, pulse width 20ms;
- Ripple Self-injection/Self-superposition;
- Offline operation ≥24H after network disconnection; seamless resumption upon network recovery;
- Multi-dimensional matrix test supported;
- Intelligent linkage with chiller, temperature chamber, pressure sensor and other third-party devices.



Parameter

Voltage	Range	0V~±6V	
	Accuracy	± 0.02% F.S	
	Resolution	0.1mV	
Current	Range	100A/200A/300A/500A...2000A	
	Accuracy	± 0.02% F.S Three levels : 25%, 50%, 100%	
	Resolution	0.1mA	
Current start response time		5ms (10%-90% F.S)	
Current switching time		10ms (-90%~90% F.S)	
Min. Working Condition Simulation Interval		10ms	
Third-party device integration		Supports linkage of temperature box, MTV/MTS, and pressure sensor	
Cabinet size (W*D*H mm)		600*850*1030 / 600*800*1980	

Note:For specific models and parameters, please refer to the corresponding technical specifications.

Advantages

- Support current is divided into three levels: 25%, 50%, 100%;
- The four-quadrant scheme is optional and can be discharged to negative 6V;
- Support multi-channel charge and discharge curve comparison;
- High power factor, low harmonic, grid-friendly;
- Supports device offline operation;
- Anti-reverse connection and data protection;
- Battery discharge and energy feedback efficiency ≥75%;
- Support 10ms working condition simulation test & pulse testing;
- Support clamp contact impedance monitoring, avoid safety problems caused by poor contact or oxidation of terminal;
- Supports the logical judgment function of specific parameter assignment.

Function Test

Cycle Life Test	Battery Capacity Test	Charging/Discharging Test	Temperature Characteristic Test
Charge Retention Test	Static/dynamic SOC Test	High-speed Working Condition Pulse Test	DCIR Test

Applications

Applied in Li-ion battery, lead acid battery, nickel-cadmium battery testing and quality control, can realize the integration of charge and discharge data monitoring.



Parameter

Model		HRCDS-100V60A-C	HRCDS-100V30A-C
Voltage	Range	0V-100V	
	Accuracy	± 0.03% F.S	
	Resolution	0.1mV	
Current	Range	±60A	±30A
	Accuracy	± 0.03% F.S	
	Resolution	0.1mA	
Current start response time		5ms (10%-90% F.S)	
Current switching time		10ms (-90%~90% F.S)	
Third-party device integration		Supports linkage of temperature box, MTV/MTS, and I/O control box	
Cabinet size (W*D*H mm)		600*800*1980	

Note:For specific models and parameters, please refer to the corresponding technical specifications.

Advantages

- Supports cell voltage consistency test;
- Supports multi-channel charge-discharge curve comparison;
- Supports multi-channel parallel function;
- Supports device offline operation;
- High power factor, low harmonic, grid-friendly;
- With reverse connection and data loss protection;
- High-quality discharge energy feedback to grid, efficiency up to 91%;
- Modular design for easy maintenance;
- Supports RS485, CAN, TTL, Single-wire and I²C communication;
- One-click DBC import;
- Customizable BMS parameters for control and protection;
- BMS voltage & current follow-up test.

Function Test

Cycle Life Test	Battery Capacity Test	Charging/Discharging Test	Charge Retention Test
Overcharge / Over-discharge Test	Temperature Characteristic Test	High-speed Working Condition Pulse Test	DCIR Test

Applications

Mainly applied to testing and quality control of smart Li-ion and lead-acid battery packs for e-bikes, drones, medical devices, self-balancing scooters and vacuum cleaners, integrating charge-discharge data monitoring in one system.













Parameter

Voltage	Range	60V-500V
	Accuracy	± 0.03% F.S
	Resolution	1mV
Current	Range	100A/150A/200A/300A/400A/600A
	Accuracy	± 0.03% F.S
	Resolution	1mA
Current start response time		3ms (10%-90% F.S)
Current switching time		5ms (-90%~90% F.S)
Third-party device integration		Supports linkage of temperature box, MTV/MTS, and I/O control box
Cabinet size (W*D*H mm)		600*800*1980

Note:For specific models and parameters, please refer to the corresponding technical specifications.

Function Test

 Cycle Life Test	 Battery Capacity Test	 Current-soc Matrix Test	 Static/dynamic SOC Test
 Charging/Discharging Test	 Temperature Characteristic Test	 BMS Follow Test	 DCIR Test

Applications

Applied in the testing and quality control of lithium battery modules & packs such as new energy vehicles, energy storage base stations, and can realize the integration of charging and discharging data monitoring.

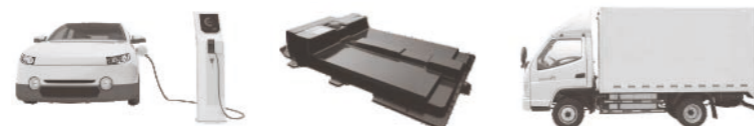

Advantages

- Support single battery voltage consistence test;
- Support multi-channel parallel;
- High power factor, low harmonic, grid-friendly;
- Anti-reverse connection and data protection;
- Battery discharge and energy feedback efficiency ≥92%;
- Modular design, easy for maintenance;
- Support RS485/CAN communication, baud rate is changeable;
- Support DBC import at one-click;
- Support user-defined BMS values as control/protection parameters;
- Support slope charging and discharging;
- User-defined login management rights are supported;
- Support four-quadrant charging and discharging function(optional).



Parameter









Voltage	Range	0V-750V-2000V
	Accuracy	± 0.05% F.S
	Resolution	1mV
Current	Range	200A/300A/400A/500A/600A/1000A...4000A
	Accuracy	± 0.05% F.S
	Resolution	1mA
Current start response time		5ms (10%-90% F.S)
Current switching time		10ms (-90%~90% F.S)
Min. Working Condition Interval		20ms
Third-party device integration		Supports linkage of temperature box, MTV/MTS, and I/O control box, and chiller
Cabinet size		As per actual configuration

Note:For specific models and parameters, please refer to the corresponding technical specifications.

Advantages

- Support single battery voltage consistence test;
- Support multi-channel parallel;
- High power factor, low harmonic, grid-friendly;
- Anti-reverse connection and data protection;
- Battery discharge and energy feedback efficiency ≥96%;
- Multilevel technology, wide voltage output, small current ripple;
- Support RS485/CAN battery pack communication protocol, CAN communication baud rate is changeable;
- Support DBC import at one-click;
- Support user-defined BMS values as control/protection parameters;
- Support slope charging and discharging;
- User-defined login management rights are supported;
- National standard plug, simulate charging pile for charging(optional).

Function Test

 High-speed Working Condition Pulse Test	 Current-soc Matrix Test	 Charge Retention Test	 Static/dynamic SOC Test
 Cycle Life Test	 Temperature Characteristic Test	 Battery Capacity Test	 DCIR Test

Applications

Applied in the testing and quality control of lithium battery modules & packs such as new energy vehicles, energy storage base stations, and can realize the integration of charging and discharging data monitoring.



Laboratory High-Voltage High-Power Battery Tester

HRCDS-750V/1000V/
1500V/2000V



Parameter

Voltage	Range	0V-750V~2000V
	Accuracy	±0.02% F.S, multi-range selectable
	Resolution	1mV
Current	Range	200A/300A/400A/500A/600A/1000A...4000A
	Accuracy	±0.02% F.S, multi-range selectable
	Resolution	1mA
Current start response time		3ms (10%-90% F.S)
Current switching time		5ms (-90%~90% F.S)
Min. Working Condition Interval		10ms
Third-party device integration		Supports linkage of temperature box, MTV/MTS, and I/O control box, and chiller
Cabinet size		As per actual configuration

Note:For specific models and parameters, please refer to the corresponding technical specifications.

Advantages

- Supports cell voltage consistency test;
- Supports multi-dimensional matrix testing such as 2D and 4D.;
- Supports peak shifting test to reduce power consumption cost;
- High-efficiency discharge energy feedback to grid, max efficiency ≥96%;
- Supports four-season cycle test;
- Supports RS485 & CAN communication with adjustable baud rate;
- One-click DBC import;
- 24-hour offline test;
- Supports national standard charging pile simulation (optional).

Function Test

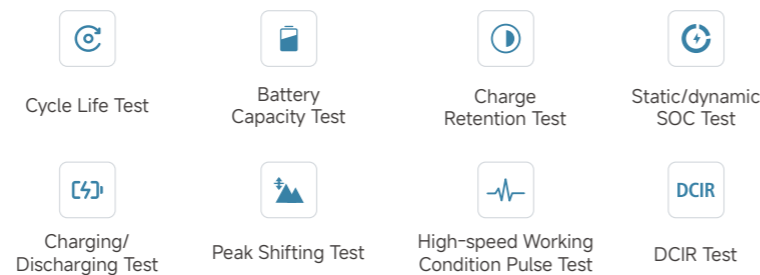

Applications

Mainly used for testing and quality control of lithium-ion and lead-acid battery packs for new energy vehicles, energy storage and PACK systems, realizing integrated charge-discharge data monitoring.



MW-Class High-Voltage High-Power Battery Tester

MRCDS-750V~2000V



High-frequency



Parameter

Voltage	Range	0V-750V~2000V
	Accuracy	±0.02% F.S
	Resolution	1mV
Current	Range	200A/300A/400A/500A/600A/1000A...4000A
	Accuracy	±0.02% F.S
	Resolution	1mA
Current start response time		3ms (10%-90% F.S)
Current switching time		5ms (-90%~90% F.S)
Power Range		600/800/1200kW (Parallel expandable up to 10MW)
Min. Working Condition Interval		10ms
Third-party device integration		Supports linkage of temperature box, MTV/MTS, and I/O control box, and chiller
Cabinet size		As per actual configuration

Note:For specific models and parameters, please refer to the corresponding technical specifications.

Advantages

- Multi-cabinet cascading, easily expandable to MW-level system;
- Supports MW-level charge-discharge test with millisecond transient control, no overshoot and no oscillation;
- Fully modular design with independent operation of each module;
- Accurately simulates fast charging condition, high-speed pulse, dynamic load and automotive-grade working condition;
- Automatic current sharing for multiple channels, delivering more stable output and higher accuracy;
- Independent intelligent energy management per channel, supporting inter-channel energy feedback for energy saving;
- Dynamic power allocation for higher test efficiency;
- Supports parallel testing of multiple products and mixed rate/working condition tests.

Function Test

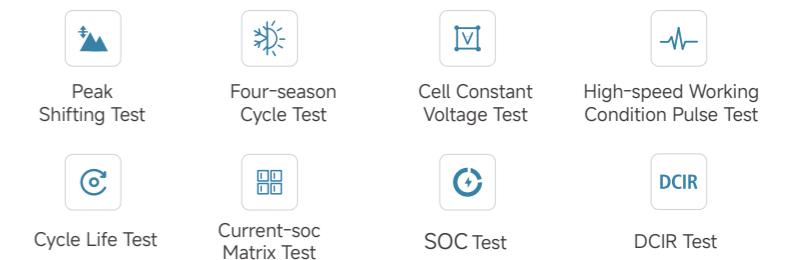

Applications

MW-level high-voltage test platform, full product coverage from 750V to 2000V. Suitable for R&D and mass production of high-voltage high-power battery packs, large energy storage systems, power battery packs, solid-state batteries and sodium-ion batteries.





Parameter

Voltage	Module	1000V Max
	PACK	2000V Max
AC withstand voltage		5kV/100mA
DC withstand voltage		6kV/7.2kV/10kV/10mA
Insulation resistance		6kV/99.99GΩ
Grounding resistance		40A/600mΩ
ACIR		0.1mΩ~3kΩ
BMS communication module	Supports CAN Communication, CAN FD, CANoe, LIN, RS232, RS485	
UDS diagnosis & unlocking	Supported	
Special custom module	Integratable with DCIR, oscilloscope, air tightness tester, etc.	
IP Rating	IP20/ IP32	
Cabinet size (W*D*H mm)	850*800*1980	

Note:For specific models and parameters, please refer to the corresponding technical specifications.

Function Test

Safety Compliance Test	Insulation resistance test, DC/AC withstand voltage test, equipotential test
Electrical Performance Test	Total voltage, total internal resistance, individual cell voltage drop, NTC accuracy, BMS power consumption
Bms Communication & Functional Test	CAN/CANFD, RS485 communication, DBC parsing, UDS diagnostics, CAN terminating resistor
Signal Simulation Test	PWM signal, collision signal, charging gun signal, high voltage interlock simulation, insulation leakage simulation

Applications

Specially designed for battery modules/PACKs of electric vehicles, buses and various energy storage systems. It integrates automated testing, data analysis and efficiency optimization functions, providing one-stop static test solutions covering production offline inspection and quality control.



Advantages

- Integrated high-precision meter, reliable and standard testing result;
- Support production verification and research-oriented test for R&D;
- High compatibility, satisfy different testing requirements on module, mono box, and PACK unit;
- Functional module is expandable as required;
- Intelligent and automatic work process to save labors and improve testing efficiency;
- Exclusive open software platform, support instruments and meters of other brands;
- Software supports the analysis of various BMS communication protocols, pass-through analyze, without any algorithm process;
- Testing function and project development can be customized as required.



Parameter

Simulated battery		High Precision Current Source		
Voltage range	0.1~6V	Current range	±200A~±1000A	
Voltage Resolution	0.01mV	Current accuracy	±0.05%F.S	
Voltage Accuracy	±0.01%F.S	Resolution	1mA	
Current range 1	Range	DC high voltage power supply		
	Resolution	0.01mA	Voltage range	0~2000V
Current range 2	Accuracy	±0.01%F.S	Resolution	100mV
	Range	0~200mA	Voltage accuracy	±0.1%F.S
Current range 3	Resolution	0.01mA	Current range	0~900mA
	Accuracy	±0.01%F.S	Programmable resistor unit	
Current range 3	Range	0~2mA	Resistance range	10Ω~12MΩ
	Resolution	0.01uA	Resistance resolution	1Ω
	Accuracy	±0.01%F.S	Resistance accuracy	±0.15% ± 1Ω

Note:For specific models and parameters, please refer to the corresponding technical specifications.

Function Test

Multi-state Power Consumption Test	Active & Passive Equalization Current Test	BMS Acquisition Accuracy Test	Fault Simulation & Detection
Digital Signal Simulation & Test	Insulation Resistance Test & Verification	National Standard Charge Signal Simulation	SOX Test

Applications

Applied in e-vehicle, battery energy storage station, BMS battery management system research, parameter calibration, verification and testing in production, and create a complete testing report.



Advantages

- Adopts Ethernet communication with fast and stable transmission speed;
- The simulated battery integrates source and load in one unit, supports charging and discharging, and can test active and passive equalization functions;
- It features multi-range, multi-gear and high-precision output, suitable for BMS calibration and accuracy comparison tests;
- Supports multiple communication protocol tests including RS232, single-line communication, RS485, CAN communication, CAN FD and Ethernet;
- Compatible with test items specified in national standards GB/T 34131-2023, GB/T 38661-2020 and other relevant standards;
- Supports secondary development; users can customize test items to improve equipment utilization;
- Modular design enables later expansion and upgrade, with convenient maintenance.

PCBA Battery Protection Board Testing Solution

PCBA-16~36S
100A/200A/300A



Parameter

Simulated battery	Voltage range	0.1-5V		
	Resolution	0.1mV		
	Voltage accuracy	±0.01%F.S		
	Current range 1	0~1A/3A	Current range 2	0~5mA
	Resolution	0.1mA	Resolution	0.1uA
	Current accuracy	±0.02%F.S	Current accuracy	±0.02%F.S
High Precision Current Source	Current range	0~100A/300A/600A... (Customizable higher current)		
	Current accuracy	±0.05%F.S		
	Resolution	1mA		
Communication unit	CAN Communication / RS485 / RS232 / Single-line communication / I ² C / SMBus, etc.			

Note:For specific models and parameters, please refer to the corresponding technical specifications.

Function Test

Balanced Current Measurement Verification	BMS Communication Detection	Quiescent Current Measurement	Protection Delay Time Measurement
Charge & Discharge Protection	On-resistance Test	Current Limiting Test	Temperature Protection Test

Applications

Applied in the testing of power battery pack protection board system, testing of PCBA performance and its technical items, and generated a complete testing report.

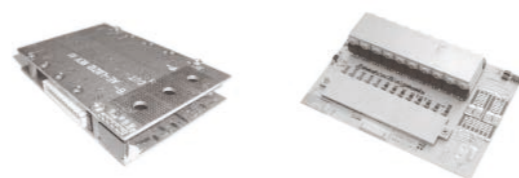

Advantages

- Composed by virtual battery, short-circuit free, safety guaranteed;
- Pluggable design of virtual battery enables it to be extended, range from 4S to 36S;
- Software supports modular setting of testing projects, production validation and research and development, research-oriented testing, and other modes, supporting secondary development;
- Support manual start testing and one click start automatic testing, including button start, barcode start, PLC start testing, etc;
- Support multi-channel independent testing to improve efficiency and production capacity.

Finished/semi-finished power Battery Testing System

GGC-60V-500V
60A~400A



Parameter

Charge voltage	Output voltage	6~60V	20~500V	Accuracy ±0.05% F.S	Resolution 1mV
	Voltage measurement	0~60V	0~500V		
Discharge voltage	Voltage measurement	0~60V	0~500V		Resolution 1mA
	Output current	0.1~60A	500A		
Charge current	Current reading	0~60A	500A		
	Output current	0.1~60A	500A		
Discharge current	Current reading	0~60A	500A		
	Output current	0.1~60A	500A		
Communication unit	CAN FD, CAN Communication, RS485, RS232, Single-line Communication, I ² C, SMBus, etc.				

Note:For specific models and parameters, please refer to the corresponding technical specifications.

Function Test

Current Calibration	Charge-discharge Over-current OCP Test	DC Internal Resistance Test	AC Internal Resistance Test
BMS Accuracy Test	Insulation Resistance Test	AC/DC Withstand Voltage Test	Over-current Delay Test

Applications

Applied in performance testing and quality control of power battery pack of e-tool, e-bike, e-motorcycle, e-vehicle, and battery module of energy storage base.



Advantages

- Soft-start for current output, avoid current shock;
- Current source open-circuit and voltage-limiting design, avoid high voltage output;
- Each channel is with independent and programmable constant voltage source and constant current source;
- Support multi-channel independent testing simultaneously, improving efficiency and production capacity;
- Support lithium battery pack solutions for the same port, different port, hardware and software versions;
- Support to read, write and comparison of Gas Gauge data in protection board of finished/semi-finished PACK;
- Software detects the battery and tests it automatically and record testing result.



Parameter

Model		RACTS-20V	ACTS-5V
Voltage	Range	2V-20V	1.5V-5V
	Accuracy	± 0.02% F.S	
	Resolution	0.1mV	
Current	Range	10mA~1A / 1A~5A / 5A~10A / 10A~40A	10mA~3A/5A/ 6A/12A/15A
	Accuracy	±0.02% F.S, multi-range selectable	
	Resolution	0.1mA	
Current start response time (10%~90% F.S)		5ms	10ms
Current switching time (-90%~90%F.S)		10ms	20ms
Third-party device integration		Supports linkage of temperature box, MTV/MTS, and I/O control box	
Cabinet size (W*D*H mm)		770*722*1800mm	

Note:For specific models and parameters, please refer to the corresponding technical specifications.

Function Test

Cycle Life Test	Battery Capacity Test	Charge Retention Test	Charge-discharge Efficiency Test
Charge-discharge Performance Test	Temperature Feature Test	Over-charge And Over-discharge Durability Capacity	DCIR Test

Applications

Applied in the testing and quality control of digital battery for notebook, digital camera, smartphone and other intelligent battery, can realize the integration of charging and discharging data monitoring.



- The current is divided into 4 levels, and the range speed is automatically switched without gap;
- Support Comparison of charge-discharge curves of multi-channel;
- With anti-reverse connection, data loss and other protection functions;
- Modular design, easy to maintain;
- Support GGS communication, I²C, SMBus, HDQ and other protocols;
- Support 100K/400K communication frequency adjustable, communication platform voltage adjustable;
- Supports multi-chip (multi-address) information reading;
- One device is able to compatible with multi-type of IC;
- Able to self-defy and load battery lock and unlock instruction for special battery.

MTVS Auxiliary Safety System

Applications

Coordinate with charge/discharge device to monitor and collect data of voltage, current, temperature, pressure of battery cell, battery module, and battery pack, to guarantee battery testing safety and performance consistency.

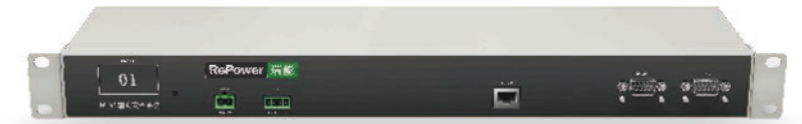

Advantages

- 40 channels of voltage, 8 channels of thermocouple temperature acquisition, 4 channels of relay output, 4 channels of I/O input;
- Modular design, able to extend measurement channel as needed;
- Support LAN, RS485 communication protocol.

Items	Channels	Testing range	Accuracy	Resolution
Voltage	40CH	0-5V/10V/20V	±0.05%F.S	1mV
Temperature	8CH	-50°C-300°C	±1°C	0.1°C
Pressure	40CH	Depend on pressure sensor range	±0.1%F.S	1mMPa
Current	40CH		±0.1%F.S	1mA

MTS Multi-channel Temperature Acquisition System

Applications

Real time monitoring and data collection on battery cell, battery module and battery pack assures the safety of battery test.



Advantages

- 40annels of thermocouple temperature acquisition, 4 channels of relay output, 4 channels of I/O input;
- Modular design, able to extend measurement channel as needed;
- The quantity of auxiliary channel can be set as needed, the auxiliary channel signal which is controlled by main channel, can be set to certain condition to stop or shift the main channel;
- The temperature, IO signal of each battery can be collected and sequenced automatically, and make judgment according to the max differentials;
- Support LAN, RS485 communication protocol;

Input power supply	220Vac±10%	
Channels	Temperature sampling	40CH
	Switch quantity input detection	4CH
	Switch quantity output detection	4CH
Temperature	Single channel measurement range	-50°C-300°C
	Measurement accuracy	±2°C
	Resolution	0.1°C
Communication mode	LAN/ RS485	

Portable EV Battery Pack Tester Analyzer

POREOL-6501EB

Portable Energy Storage System Safety Tester Portable Power Battery Pack EOL Tester

POREOL-6501ESS
POREOL-6501EV



Parameter

Insulation resistance	1kV/10GΩ
Charging voltage range	0V~40V;40V~80V
Charging voltage accuracy	±0.05% F.S.
Charging current range	0mA~4000mA
Charging current accuracy	±0.05% F.S.
Discharge voltage range	5V~80V
Discharge voltage accuracy	±0.05% F.S.
Discharge current range	0mA~4000mA
Discharge current accuracy	±0.05% F.S.
Supported communication methods	CAN Communication, Single-line Communication, RS485...
Remote OTA function	Have
Noise	<60dB
Cabinet size	506*407*727.5(W*D*H mm)
Equipment weight	<35kg

Note:For specific models and parameters, please refer to the corresponding technical specifications.

Function Test

Multiple Communication Methods	Undervoltage Battery Activation	Charge/discharge Test	Total Voltage Detection
Voltage and Differential Voltage Detection	Temperature and Temperature Difference Detection	DC Impedance Detection	Manufacturer Information Reading
Casing Insulation Test	MOSFET Function Test	Health Status Reading and Assessment	Power Adjustment

Advantages

- 1. Specially designed for battery packs of two/three-wheelers and electric motorcycles;
- 2. Compact and intelligent, it simplifies testing and improves maintenance efficiency;
- 3. Supports customized functions tailored with battery manufacturers;
- 4. Optimize full-process safety management and screening of battery packs;
- 5. Suitable for production test, maintenance, safety inspection, recycling and secondary utilization;
- 6. Automatically collects, analyzes and processes battery data with integrity, traceability and high reliability.

Applications

Portable Battery Pack Inspection and Analysis Equipment enables fast, accurate, and multifunctional detection of battery pack health status, providing a comprehensive solution from problem diagnosis and data analysis to opinion processing. It is mainly applied in the full lifecycle of two/three-wheeled vehicle battery packs, including production, operation management, after-sales maintenance, and recycling.



Parameter

Input Power	220Vac/50Hz
AC Withstand	5kV/20mA
DC Withstand	6kV/10mA
Insulation Resistance	6kV/50GΩ
Voltage	Range: 200mV~1000V, Resolution: 6 ^{1/2} , Accuracy:0.01%
Resistance	Range: 0~200kΩ, Accuracy: 0.05%; Range: 200kΩ~10MΩ, Accuracy: 1%;
Power Output	AC: 220V*1、DC: 12V*1、DC: 24V*1
Communication	CAN FD*2 Baud rate:40K~5Mbps
IP Rating	IP32
Noise	< 70dB
Cabinet size	485*870*412mm (W*H*D)
UPS Capacity	Standby time: ≥8H Operating: ≥4H

Note:For specific models and parameters, please refer to the corresponding technical specifications.

Advantages

- 1. Highly compatible for testing power battery packs, energy storage systems and power stations;
- 2. Rich external interfaces cover insulation withstand voltage, total voltage detection, CAN communication, etc.;
- 3. 28-inch suitcase size with silent casters for easy single-person handling;
- 4. Built-in UPS provides 8-hour standby and 4-hour continuous operation during power failure;
- 5. IP32 protection rating suits both indoor and outdoor use.

Applications

It is mainly applied to inspection and maintenance of battery packs for electric vehicles, grid user-side energy storage power stations, transformer area and aftermarket container energy storage, household and mobile energy storage, as well as warehouse battery pack sampling inspection and factory return maintenance.



Function Test

Safety Test	Voltage Test	Ground Resistance Test	Compliance Test
Surface Temperature Measurement	Communication Test	Relay Function Test	Total Voltage Accuracy Test
Programming/Upgrading	Compliance Test	BMS Functional Test	UDS Communication Test

Portable Cell Charge-Discharge Maintenance Tester



Parameter

Power Supply	90Vac-264Vac
Grid Frequency	48-62Hz
Detection Range	Single Cell 0-5V
Charging Voltage Setting	0-5V (Adjustable)
Charging Current Setting	0-60A (Adjustable)
Discharging Voltage Setting	0.5-5V
Discharging Current Setting	0-60A (Adjustable)
Operating Mode	Charging Mode / Discharging Mode
Charging Mode	Constant Current Constant Voltage
Discharging Mode	Constant Current Constant Voltage
Operating Temperature	-20~+55°C
Cooling Method	Air Cooling

Note:For specific models and parameters, please refer to the corresponding technical specifications.

Function Test



CC-CV Charging



CC-CV Discharging



Cell Balancing



Capacity Calibration



Advantages

- Combines charging and discharging in one unit, fulfilling all test and maintenance needs for battery packs.
- Supports custom multi-level stop protection thresholds; auto-monitors and activates protection for unattended full testing.
- Lightweight and portable, with built-in screen for real-time charge-discharge data to quickly check cell condition and quality.
- Optional RS485 data transmission interface, supports data logging and remote control.

Applications

This high-precision lithium cell maintenance and tester has a built-in precision power supply, supporting CC-CV charge and discharge. It rapidly regulates over/undervoltage cells with no cross-voltage limit for easy cell balancing. It also delivers accurate capacity calibration, perfect for cell replacement, performance testing and regrouping.

Portable Battery Charge-Discharge Maintenance Tester

PTCDS-450V60A-7kW



Parameter

Input	Voltage Type	Three-phase+N+PE
	Voltage Range	175Vac~265Vac
	Grid Frequency	40Hz-70Hz
Output	Output Voltage Range	10Vdc-450Vdc
	Output Current Range	0-60A
	Max Output Power	7kW
	Voltage Accuracy	±0.05%
	Current Accuracy	≤±0.1%
Battery BMS Communication	Supports CAN Communication; reads and parses BMS CAN messages, with BMS data as charge/discharge stop conditions	
Ambient Temperature	-20°C~+55°C	
Relative Humidity	≤95%RH, Non-condensing	
Cooling Method	Air cooling	
Cabinet size	530*340*240mm(W*H*D)	

Note:For specific models and parameters, please refer to the corresponding technical specifications.

Advantages

- Wide voltage design, compatible with multi-voltage battery packs.
- Adopts bidirectional power technology for high-efficiency charging; auto grid-connected discharge to save energy.
- Generates battery voltage curve; data supports internal storage and USB export for easy traceability.
- Integrated BMS communication to sample single cell voltage and temperature of battery modules.
- Dual protection design for grid and battery sides.
- Supports CAN protocol and mainstream BMS connection; compatible with external acquisition modules and harnesses, with OTA and PC upgrade available.

Applications

A professional device tailored for the full life-cycle maintenance of battery modules. Adopting advanced grid-connected discharge technology and integrated multi-function design, it features compact size, light weight and high portability. It supports charge-discharge testing of battery modules as well as voltage and temperature sampling & storage of single cells, delivering an efficient, accurate and all-in-one solution for battery maintenance.



Module Charge-Discharge Test



Single Cell Monitoring



Portable Battery Pack Charge-Discharge Maintenance Tester

PTCDS-1000V70A-22kW
PTCDS-1000V140A-40kW



Parameter

Model	PTCDS-1000V70A-22kW	PTCDS-1000V140A-40kW	
Voltage Type	Three-phase+N+PE		
Voltage Range	260Vac~530Vac		
Grid Frequency	45Hz~65Hz		
Output Voltage Range	30~200V	200~1000V	150~1000V
Output Current Range	0~100A	0~70A	0~140A
Max Output Power	22kW		40kW
Voltage Accuracy	±0.5%		
Current Accuracy	≤±1%		
Battery BMS Communication	Supports CAN Communication, RS485; Reads and parses BMS CAN messages, with BMS data as charge/discharge stop conditions.		
Ambient Temperature	-20°C~+55°C		
Relative Humidity	≤95%RH, Non-condensing		
Cooling Method	Air cooling		
Cabinet size	450*600*900mm (W*H*D)		

Note:For specific models and parameters, please refer to the corresponding technical specifications.

Function Test

Charge-Discharge Test	Voltage Test	Battery Pack Relay Control	Data Logging
Cycle Life Test	Temperature Test	Communication Test	Barcode Scanning Test

Advantages

- Wide voltage design, applicable to charge-discharge tests of battery packs with different voltage levels;
- Real-time acquisition of single cell voltage and pack terminal voltage;
- Automatically saves charge-discharge history and supports data export in Excel format;
- Preset working mode, battery type, voltage threshold, working current and other parameters; one-click to call and start the test;
- Real-time monitoring during charging and discharging: single cell voltage, pack terminal voltage, current, charge/discharge status and capacity.

Applications

Quickly realizes voltage matching for power battery packs, energy storage battery clusters and storage cabinets. It supports daily maintenance and capacity calibration of battery packs and modules. Full-process data viewing and report generation are available, suitable for charge, discharge and cycle tests of mainstream lithium battery packs.

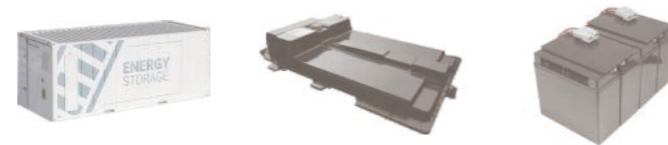

NEV Charging & Electrical Safety Tester

EVTS-060F2S1
EVTS-090F2S1
EVTS-120F2S1



Parameter

Electrical Safety	Insulation Resistance Test Range	DC 100V~1000V / 0.1MΩ~50GΩ
	Voltage Output Accuracy	±1% ± 5V
	Voltage Measurement Accuracy	DC 100 V~DC 499 V, ±2% DC 500 V~DC 1000 V, ±1%
	Potential Equalization Test Current Range	DC 0.1A~2.0A
DC Charging	Resistance Test Range	10mΩ~2000mΩ
	Resistance Test Accuracy	±1% or ±0.01Ω
	DC Charging Range	DC 150V~1000V 0A~250A
	Rated Output Power	60kW/90kW/120kW Max.
AC Charging	DC Voltage Measurement Range	DC 0V~1000V
	DC Voltage Regulation Accuracy	≤ ±0.5%
	DC Charging Gun	Dual Guns
	Rated Input Voltage: 220V	Charging Gun
Rated Output Current: 32A	Max Current: DC250A/AC32A	
Rated Output Power: 7kW	CAN Communication: 3-way	

Advantages

- Supports simultaneous test of dual DC and AC guns; max 120kW charging power with intelligent distribution.
- Fast, high-precision test, exceeding national standard;
- Full automatic test, no cable reconnection required;
- Complies with GB/T 44500-2024, compatible with new and old GB/T 27930 vehicle testing;
- Multi-scenario use, high utilization, low maintenance and long economic benefit;
- Multi-channel CAN communication real-time monitors voltage, current and temperature for stable data interaction;
- Equipped with leakage, overcurrent, short-circuit and lightning protection for instant power cut-off;
- IP54 protection level, applicable for indoor and outdoor use;
- Real-time test curves and battery status display; complete test report generated automatically.

Function Test

Electric Shock Protection	Insulation Resistance
	Potential Equalization
Power Battery Safety and Performance	Cell Consistency
	Cell Safety
	SOC Estimation Accuracy
	BMS Indication Accuracy
	Battery Aging Level
	Specific Fault

Applications

NEV charging and electrical safety inspection equipment fully complies with latest regulation requirements. It conducts comprehensive safety performance testing and health analysis for new energy vehicles, and outputs authoritative test reports. Suitable for inspection institutions, vehicle manufacturers in R&D, production and after-sales scenarios.

High-Voltage Series Formation Solution

Advantages

RePower's battery series connection formation & grading system is an energy-saving and efficient production line solution. The self-developed switching unit can be arbitrarily connected in series and the single channel is independent with higher sampling accuracy and quicker response time. RePower is the first company in industry to adopt the high-frequency SiC technology, which can make the equipment size smaller and the power density higher. It is convenient to install and maintain the equipment, and also help battery factories to reduce the costs and improve the products quality.

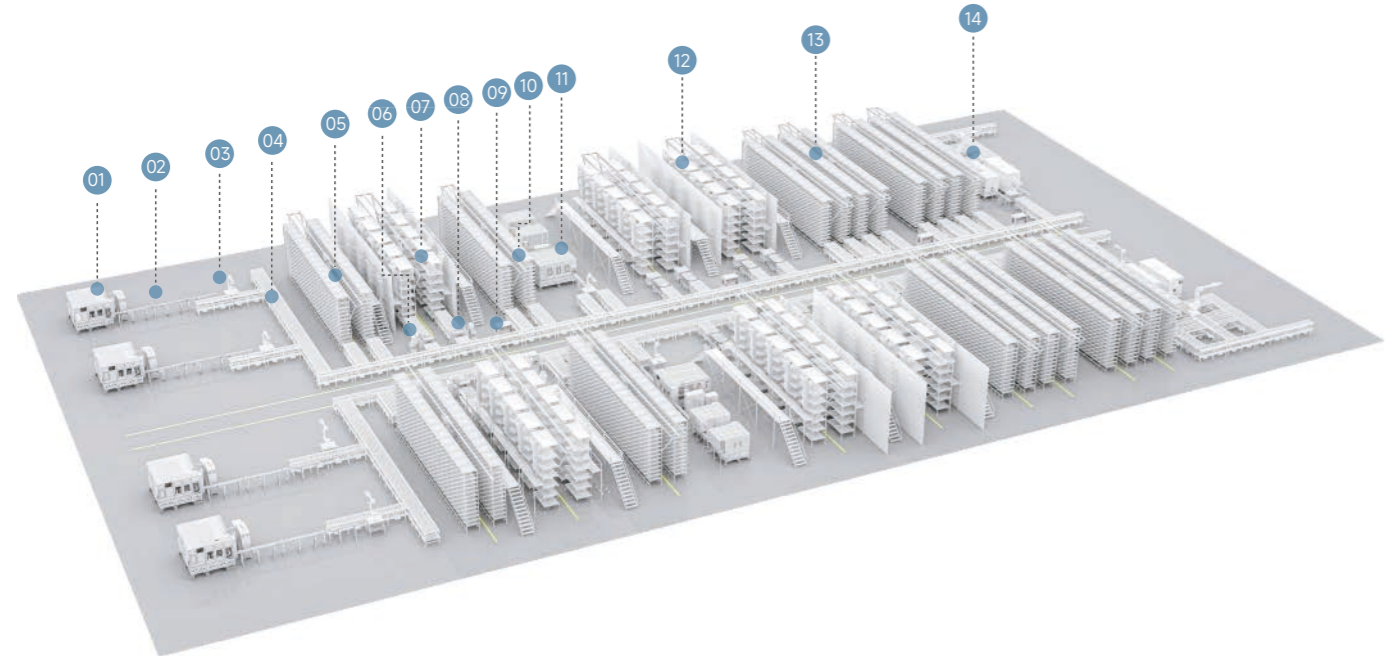

- 01 First injection
- 02 Injection unloading
- 03 Battery pack
- 04 Conveyor belt
- 05 High temperature static storage
- 06 Pin Pulling
- 07 Series connection formation
- 08 Pin Inserting
- 09 OCV
- 10 Normal temperature static storage
- 11 Secondary injection Sealing welding Airtightness detection
- 12 Battery grading
- 13 Normal temperature static storage
- 14 Cells sorting

High frequency and high voltage power module



Independently developed high frequency and high voltage power module, using high frequency silicon carbide technology, small size, high power density; Applicable to different layout requirements of the production line, the power part can save more than 50% space.

Switchboard

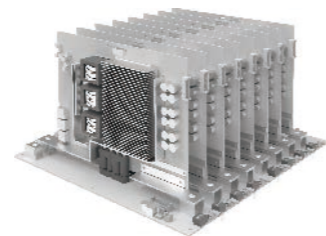

The switchboard supports any number of series, the maximum number of series can be supported up to 120 series. Single channel independent control of switching board, fast acquisition/judgment, fast disassembly and replacement.

Solution Advantages

High voltage series system

The equipment adopts high voltage series system, up to 800V busbar technology.

High cell consistency

The current of the series circuit is highly consistent, effectively improving the consistency of the cell;

Small space volume

High frequency silicon carbide technology, small size, high power density, power part can save 50% space;

High equipment efficiency

Adopts a high-voltage module, with a charge-discharge efficiency of up to 96%, saving significant electricity costs;

Low wire cost

The high-voltage series scheme can greatly simplify the cable, reduce the cost and loss of wire, while significantly decreasing commissioning workload;

Heat energy recycling

The thermal energy cycle technology is adopted to realize the stable operation of the power supply under high temperature environment, and realize the heat recovery and utilization of the power supply synchronously.

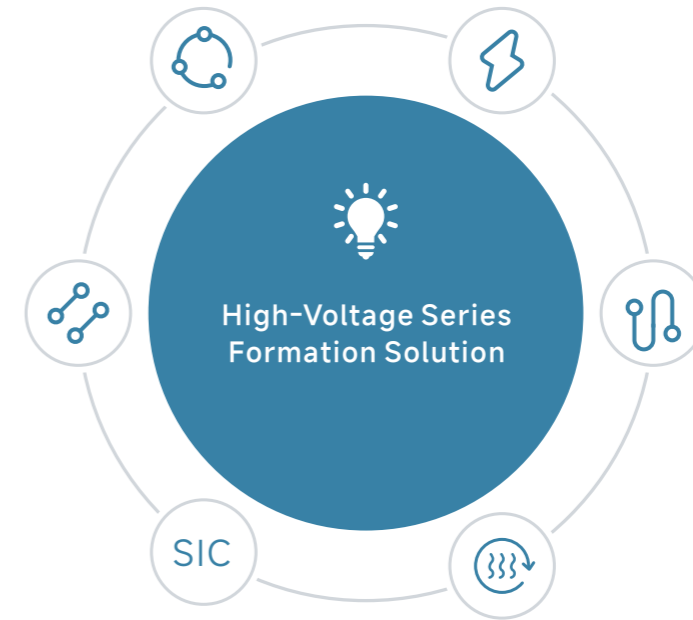

Single channel principle of series circuit

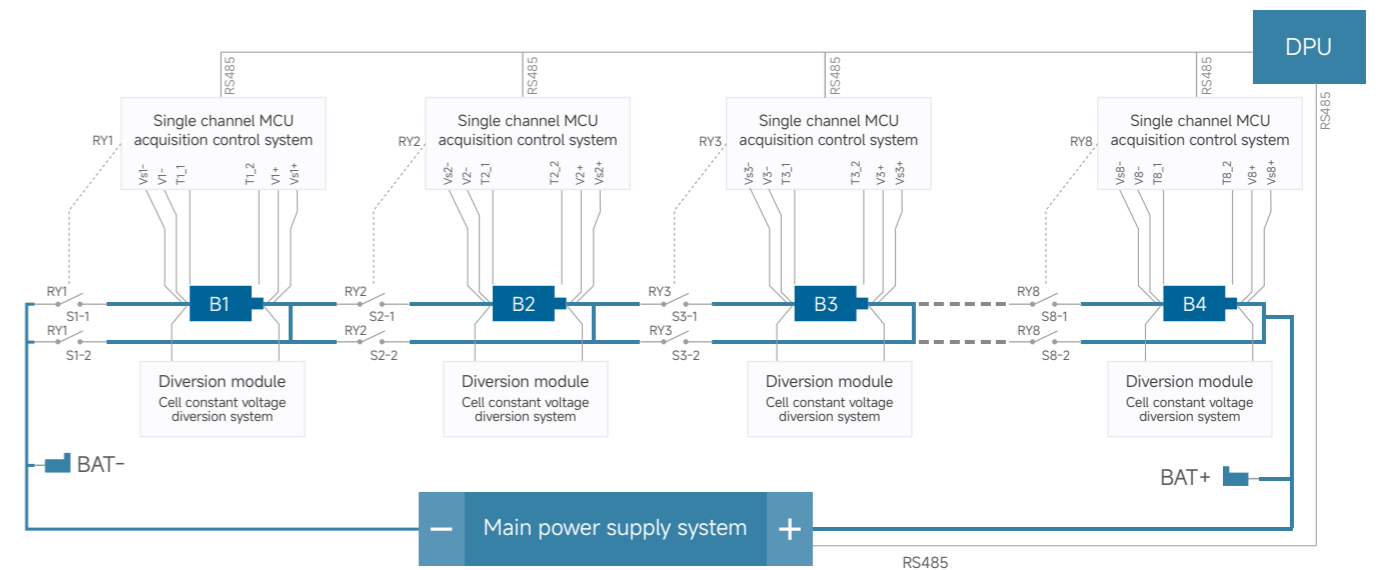

Battery Pack Automated Production Line Solutions

Layout

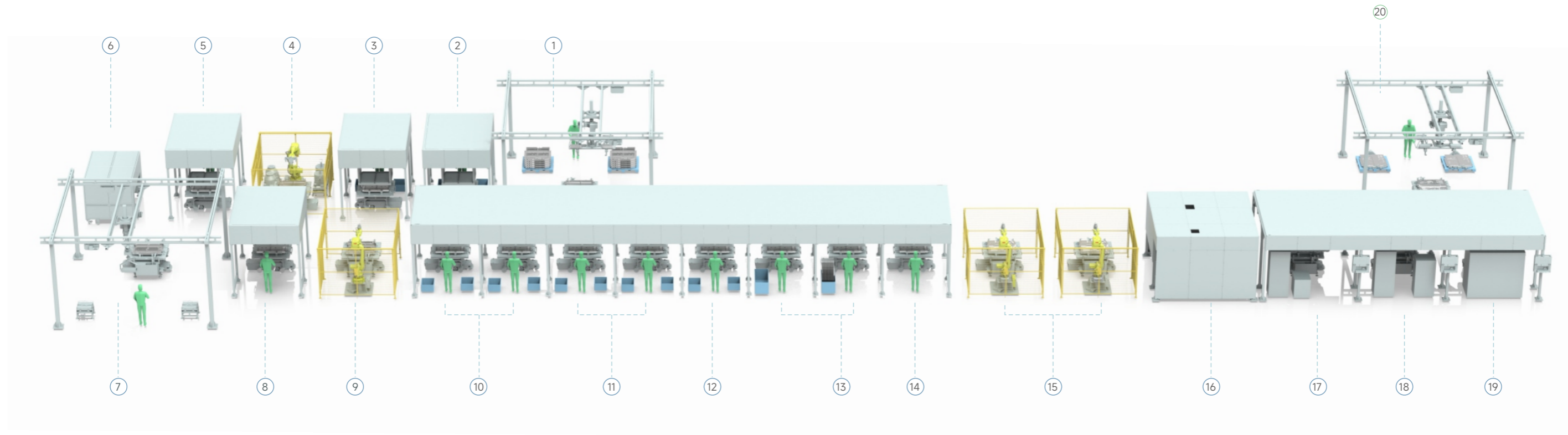

Process

■ Fully automatic station
 ■ Semi-automatic station
 ■ Manual station

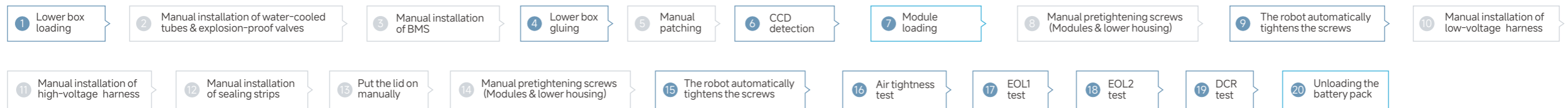





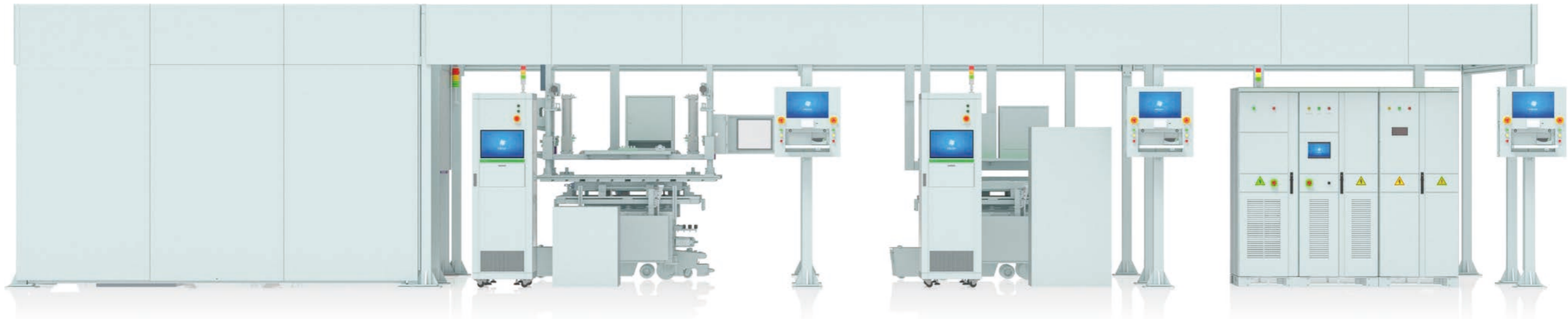

Battery Pack Automated Production Line Solutions

Layout

PACK integrated test line is composed of air tightness test station, EOL test station and DCR test station. It is mainly used for battery pack insulation voltage test, BMS communication test, DCR test, water-cooled box airtightness test, battery pack total voltage test and other performance verification tests.



Advantages

-  The sealing design of air tight test reduces the influence of gas flow on air tight test and improves the accuracy of air tight test.
-  Air-tight press design to avoid expansion during Pack test.
-  EOL test has airtight wake-up function.
-  Realize automatic insertion, automatic testing, no manual intervention.
-  One-stop solution of PACK offline function comprehensive test.
-  Compatible with multiple battery production tests.

Air tightness test (Water cooled & box)

- Water-cooled housing & air-tight test all-in-one machine
- Battery pack press module
- Air tight low voltage wiring harness adapter box
- Harness homing detection module

EOL1/ EOL2 Test

- Dual channel EOL test system
- Battery pack press module
- EOL high and low voltage wiring harness adapter box
- Harness homing detection module
- Battery pack safety detection module
- Battery pack static function detection module
- Battery pack dynamic function detection module

DCR test

- DCR test system
- DCR high and low voltage harness adapter box
- Harness homing detection module
- Safety monitoring (temperature detection, smoke detection)
- Collision detection module

Process



After-sales Service

Wechat after-sales service system

- One machine, one code, ensure precise repair reporting
- Real time review of repair progress
- Professional engineer, quick online response
- Complaint evaluation, with guaranteed supervision



Wechat after-sales service system

Service pledge

Quick response

After receiving the repair order, the customer service center will respond quickly in 2 hours and provide solutions in 8 hours.

Quick problem-solving

Service outlets are spread throughout the country, and if needed, we can quickly come to solve problems.

Technical support

Provide technical support and provide control software upgrade services until the device hardware cannot support it.

Service Network

RePower has its headquarter in Shenzhen, its branch offices, agents and technical support network covers South China, North China, East China and Southwest China.

RePower bases itself upon domestic market and aims at the world. It established overseas sales team for the global market. RePower now has its distributors and agents in Asia, Europe, and America, etc.



Service Network Branches:

Japan / South Korea / India / Vietnam / Indonesia / Singapore / Germany / Italy / United States

Application Cases

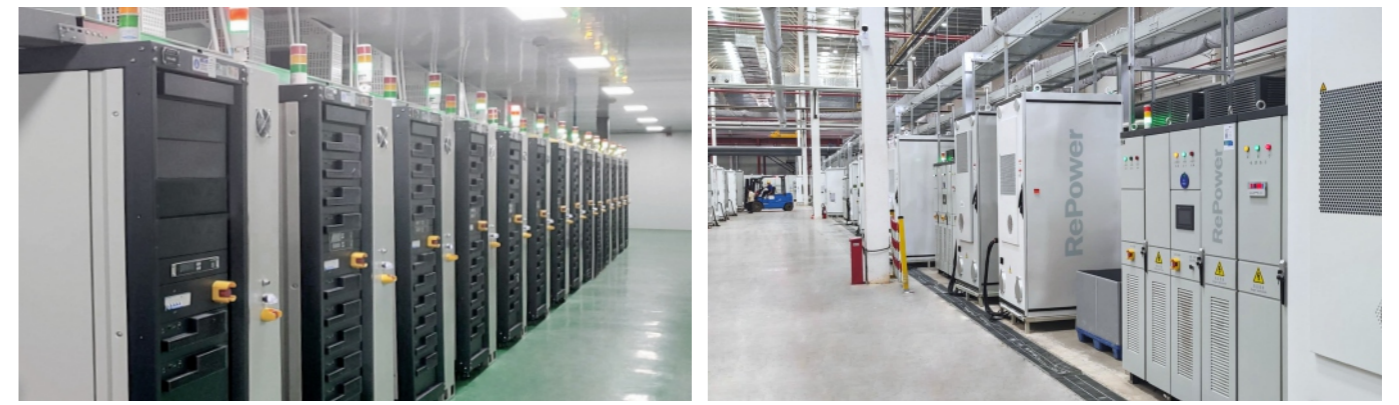

Application Cases

